

THE FOURTH UTILITY

A Universal Premises Wiring System for Intelligent Buildings

IS 2001-06

THE FOURTH UTILITY

A Universal Premises Wiring System for Intelligent Buildings

Report Date: April, 2001

Reprint Date: July, 2001

This report was written by Elmer H. Hara and Pieter Van Vliet, and is published by CABA with permission by the authors. CABA expresses its appreciation to Elmer H. Hara and Pieter Van Vliet for making this report available for inclusion as part of CABA's INFORMATION SERIES.

Neither Elmer H. Hara, Pieter Van Vliet, nor CABA, nor any other person acting on their behalf assumes any liability with respect to: the use of, or for damages resulting from the use of, any information, equipment, product, method or process disclosed in this report.

This full report and other INFORMATION SERIES reports appear on CABA's Web site "Member's Lounge": (<http://www.caba.org>), and are available to CABA Members. This information is also keyword searchable. Contact the CABA office if you do not have the passwords to access this material email caba@caba.org or phone 1-888-798-CABA [2222]. CABA requests that its express written consent be obtained prior to the reproduction, in whole or in part, of any of its INFORMATION SERIES publications.



THE FOURTH UTILITY

A Universal Premises Wiring System for Intelligent Buildings

ABSTRACT

The Fourth Utility refers to the telecommunication infrastructure and services of a building. The first three utilities are water (plumbing), electricity (wiring) and air (HVAC: Heating Ventilating & Air Conditioning). The telecommunication infrastructure not only includes telephone and data but all of the signal & control facilities such as those for HVAC, access control, fire detection & alarm and security monitoring.

The construction industry, developers and architects have yet to appreciate the importance of treating the telecommunication infrastructure as a single entity if they wish to fully satisfy the Fourth Utility needs of modern buildings, in particular, intelligent buildings.

A universal premises wiring system capable of serving as the Forth Utility of an intelligent building is discussed in this paper. The system is based on a multimedia multiplexer, fiber-optic star-network and short distance wireless interconnections. Well-established technologies are employed in the design.

The Fourth Utility system discussed here can replace more than 80 % of the telecommunication copper-wires in a building. The system is universally transparent and corresponds to Layer-1 (i.e. Physical Layer) of the 7-Layer OSI (Open System Interconnect) model. The costs of maintenance, upgrades and alterations can be reduced by more than a factor 2 over the lifetime of a building.

Elmer H. Hara, Ph.D.

NET-FIVE TELECOM CORPORATION

Pieter Van Vliet, P.Eng.

CANADIAN INSTITUTE FOR

BROADBAND AND INFORMATION NETWORK TECHNOLOGIES

44 Cannington Mews

Regina, SK, Canada

S4S 5Z7

Tel. (306) 584-8301

Fax (306) 585-4855

e-mail: Elmer.Hara@uregina.ca

CONTENTS

THE FOURTH UTILITY

A Universal Premises Wiring System for Intelligent Buildings

	[Page]
1. INTRODUCTION	1
2. FOURTH UTILITY	1
3. FIBER-OPTIC STAR-NETWORK PREMISES WIRING SCHEME	1
4. FIBER-OPTIC MULTIMEDIA MULTIPLEXER	3
5. FIBER-OPTIC & WIRELESS HYBRID UNIVERSAL PREMISES WIRING SYSTEM	4
5.1 Computer & Control Room	4
5.1.1 HVAC and Lighting Control Systems	6
5.1.2 Access Control and Pager Systems	6
5.1.3 Fire Detection and Mist-Sprinkler Control Systems	6
5.1.4 Door & Window Security Contact Monitoring System	8
5.1.5 CCTV Premises Monitoring System	8
5.1.6 Cable TV	8
5.1.7 Telephone Service	8
5.1.8 Data Services, LANs and High Speed Ethernet LANs	9
5.1.9 Network Manager	9
6. ADVANTAGES	10
7. DISCUSSION	11

APPENDIX

FIBER-OPTIC MULTIMEDIA MULTIPLEXER

A-1. INTRODUCTION	14
A-2. FIBER-OPTIC MULTIMEDIA MULTIPLEXER	14

1. INTRODUCTION

New developments in telecommunication and multimedia technologies have forced many buildings to overlay new wiring, or rewire at significant cost. In addition, these new installations may need upgrading or replacement within 5 years because of the ever-increasing demand for higher transmission speeds and larger capacities created by high speed (e.g. 1.4 GHz) PCs (Personal Computers) and 100 MHz as well as GHz LANs (Local Area Networks).

Many of the raceways and conduits in a building have been filled to capacity by repeated overlays and rewiring. Furthermore, large sections of the wiring routes are unknown in many buildings because of poor record keeping. Reuse of old wiring is usually difficult and after some years, installation of new wiring becomes next to impossible.

Clearly, there is a need for a universal premises wiring system that can support present and future telecommunication requirements of a building in an economical manner. The idea of dealing with all of the telecommunication needs of a building as a whole, leads to the concept of Fourth Utility, which is discussed in the following section.

2. FOURTH UTILITY

The Fourth Utility refers to the telecommunication infrastructure and services of a building. The first three utilities are water (plumbing), electricity (wiring) and air (HVAC: Heating Ventilating & Air Conditioning). The telecommunication infrastructure not only includes telephone and data but all of the signal & control facilities for building management such as those for HVAC, access control, fire detection & alarm and security monitoring.

Many of the Fourth Utility needs of a building are listed in Table 1. It is by no means exhaustive. A universal premises wiring system to serve as the backbone of a Fourth Utility should be flexible enough to support future developments in office equipment, building management and telecommunication systems.

Ideally, the Fourth Utility needs of an intelligent building should be supported throughout the lifetime of the building. Upgrades and alterations must be economical and simple to implement. The following section discusses a star-network that can meet most of these demands.

TABLE 1
FOURTH UTILITY NEEDS OF A BUILDING

- Telephone & Data
- LAN
- High Speed Terminal to Main-Frame Interconnection
- HVAC
- Fire & Smoke Detection
- Fire Alarm
- Security Telephone
- Door & Window Security Contact Monitoring
- Access Control
- Public Address System
- CCTV (Closed Circuit TV)
- Cable TV

3. FIBER-OPTIC STAR-NETWORK PREMISES WIRING SCHEME

Figure 1 shows a premises wiring scheme based on a fiber-optic star-network. It offers high reliability and the flexibility required of a Fourth Utility for an intelligent building.

Remote-multiplexer and main-multiplexer pairs form the arms of a star-network. Fiber-optic cables with twin multimode-fibers interconnect the pairs of multiplexers that operate in a bidirectional manner.

The signal channels from office equipment such as telephone, facsimile and PCs are connected to remote-multiplexers through short copper-wire cables. Sensors and control units for HVAC and other building management systems are also connected to the remote-multiplexers in the same fashion.

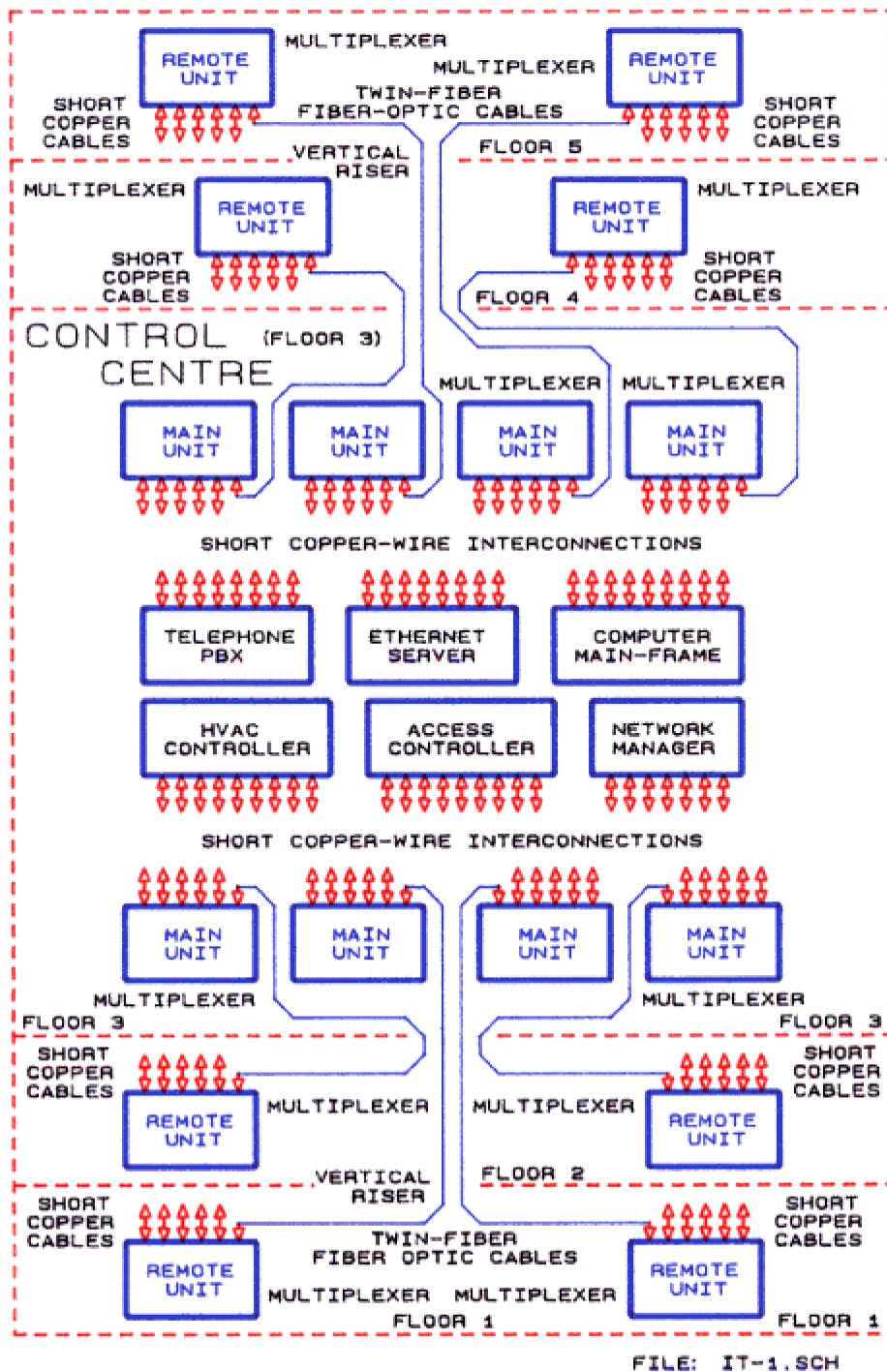

FIG. 1 STAR-NETWORK PREMISES WIRING SCHEME

The remote-multiplexer multiplexes all the channels into a single bit-stream that is then routed to the Control Centre through fiber-optic cables with twin multimode-fibers. The multiplexed channels are separated back into their original channels by the main-multiplexer.

Short copper-wire cables are used between the main-multiplexers and Fourth Utility systems, which include telecommunication systems such as telephone PBXs (Private Branch Exchanges), LANs, and building management systems such as HVAC and access controllers.

The remote & main multiplexer-pairs use a wide range of plug-in interface cards to accommodate the copper-wire cable connections. Digital signals ranging from DC contact closures to 20 Mb/s for links to computer mainframes can be supported. Higher bit rates can be accommodated as well.

Interface cards can also accept analogue signals such as stereophonic audio and baseband video signals. Of course, the signals are digitized first within the interface card before a multiplexer multiplexes them. The digitized signals are converted back to analogue signals by a matching interface card in the corresponding multiplexer.

The star-network described here corresponds to Layer-1 (Physical Layer) of the OSI (Open System Interconnect) 7-Layer Model established by ISO (International Standards Organization).

Since the ends of the star-network arms are copper-wire cables, all standard connections can be supported. In effect, the multiplexer pairs become transparent to the application engineer. As far as the engineer is concerned, the network can be viewed as a collection of independent networks wired with copper-wire cables.

In effect, the fiber-optic star-network, formed by the remote-multiplexer and main-multiplexer pairs, provides a universal premises wiring scheme. Adding or changing interface cards accomplishes upgrades and wiring changes. In other words, the operation is reduced primarily to an unplug and/or plug-in operation.

High reliability is another advantage of the star-network. If one pair of multiplexers malfunc-

tions, only a small section of the building is affected. Of course, such malfunctions can be detected and displayed immediately by the Network Manager PC that monitors the operational status of all multiplexer pairs, including the status of each interface card.

The key to realizing such a universal premises wiring system is the multiplexer, which is discussed in the following section.

4. FIBER-OPTIC MULTIMEDIA MULTIPLEXER

A multiplexer that can support the wide range of telecommunication needs of a Fourth Utility for an intelligent building must have sufficient transmission capacity.

For a star-network, the overall transmission capacity of the network is the aggregate of each arm of the star-network. Therefore, even if each of the multiplexer pairs supports only 100 Mb/s, the five-story building in Fig. 1 will have a capacity of

$$100 \text{ Mb/s} \times 8 = 800 \text{ Mb/s} .$$

To carry 100 Mb/s per arm in the star-network, fiber-optic cables with multimode fibers are the logical choice because of their relative ease in attaching connectors. Also, low-cost optoelectronic components such as LEDs (Light Emitting Diodes) can be used with multimode fibers.

Cables with twin-fibers are utilized to provide bidirectional transmission, which can also be achieved with single-fibers by using WDM (Wavelength Division Multiplex) devices. However, WDM systems for short distances tend to be more expensive than systems that use twin-fibers because of the cost of WDM devices.

The multiplexer for the Fourth Utility must also be flexible and support a wide range of analogue and digital signals from DC to 10 MHz to above 50 Mb/s.

As mentioned earlier, interface cards can be used to accommodate these multimedia signals but a versatile multiplexer is required. The design of such a fiber-optic multimedia multiplexer is discussed in the Appendix.

Obviously, the fiber-optic star-network could be converted into a much more attractive choice as a universal premises wiring system with the addition of a wireless interconnection scheme. The following section discusses such a system.

5. FIBER-OPTIC & WIRELESS HYBRID UNIVERSAL PREMISES WIRING SYSTEM

Figure 2-A shows the upper floor sections of a Fiber-Optic & Wireless Hybrid Universal Premises Wiring System that was designed to serve a 61-story office building in Singapore. (Regretfully, the system was not installed because of budgetary constraints.) The layout of the lower floors is identical to that of the upper floors.

Four remote-units of fiber-optic multimedia multiplexers are used to support all of the Fourth Utility needs of a floor. Each of the multiplexer pairs has a capacity of 100 Mb/s. Short copper-wire cables are used to connect office and desktop equipment to interface cards in the remote-multiplexers. Similarly, building management systems such as HVAC are also connected to appropriate interface cards. Copper-wires can be used to connect PCs to a LAN interface card (e.g. Ethernet bridge) as well.

Alternatively, telephone and low-bit rate signals such as 56 kb/s and 144 kb/s to PCs can be supported by wireless systems. They are based on 2.4 GHz digital spread spectrum technology used by digital cordless telephones and PCS (Personal Communication System) telephones.

Here, the required reach of the wireless system is less than 50 m. Therefore, the RF (Radio Frequency) output power can be kept low and government licensing is not needed. Furthermore, the RF spectrum allocation can be repeated on alternate floors because of the low output power.

By using the automatic channel scanning system employed by cordless telephones, the available spectrum can be utilized efficiently. In fact, the wireless telephone for this application can be identical to 2.4 GHz digital spread spectrum cordless telephones with the base station (i.e. wireless modules) circuitry modified to receive digital signals (e.g. 56 kb/s) directly.

Remote PBX nodes are connected to a PBX through T1 = 1.544 Mb/s channels. They demultiplex the T1 channels into individual telephone and data lines, and supply them to the wireless modules. Since the telephone and data lines are obtained directly from T1 = 1.544 Mb/s channels through the multimedia multiplexer, there is no need for analogue to digital conversion at the wireless modules.

The digital wireless telephone can be designed for $B = 64$ kb/s voice only, or include a $D = 16$ kb/s data channel for extra functions such as call-display and call-waiting. By expanding the wireless telephone capacity to $2B + D = 144$ kb/s or $2B + 2D = 160$ kb/s, the telephone set can serve as a "modem" for other office equipment such as PCs. Such digital telephones supporting direct input/output of $B + D$, $2B + D$ and $2B + 2D$ signals may still be more of a laboratory curiosity today but they can be produced in quantity with little difficulty.

Wireless modules for T1 = 1.544 Mb/s can also be used to support high-speed interconnections from PCs to the Internet. Wireless LAN nodes based on optical or GHz frequencies can also be used. Interaction of the nodes on the same floor is avoided by using different optical wavelengths or carrier frequencies. Optical wireless nodes may be more advantageous because interference with other floors will not occur.

All the Fourth Utility signals to and from every floor are routed through the fiber-optic cables to the 31st floor where the Computer & Control Room is located. This room is discussed in the following section.

5.1 Computer & Control Room

Locating the Computer & Control Room in the middle floors of a building somewhat simplifies the layout of fiber-optic cables by limiting their maximum lengths. Also, the room is much more secure than the case where Fourth Utility equipment is located in the basement. All building designers should take to heart, the damage caused to the World Trade Center in New York by a bomb in the underground parking garage.

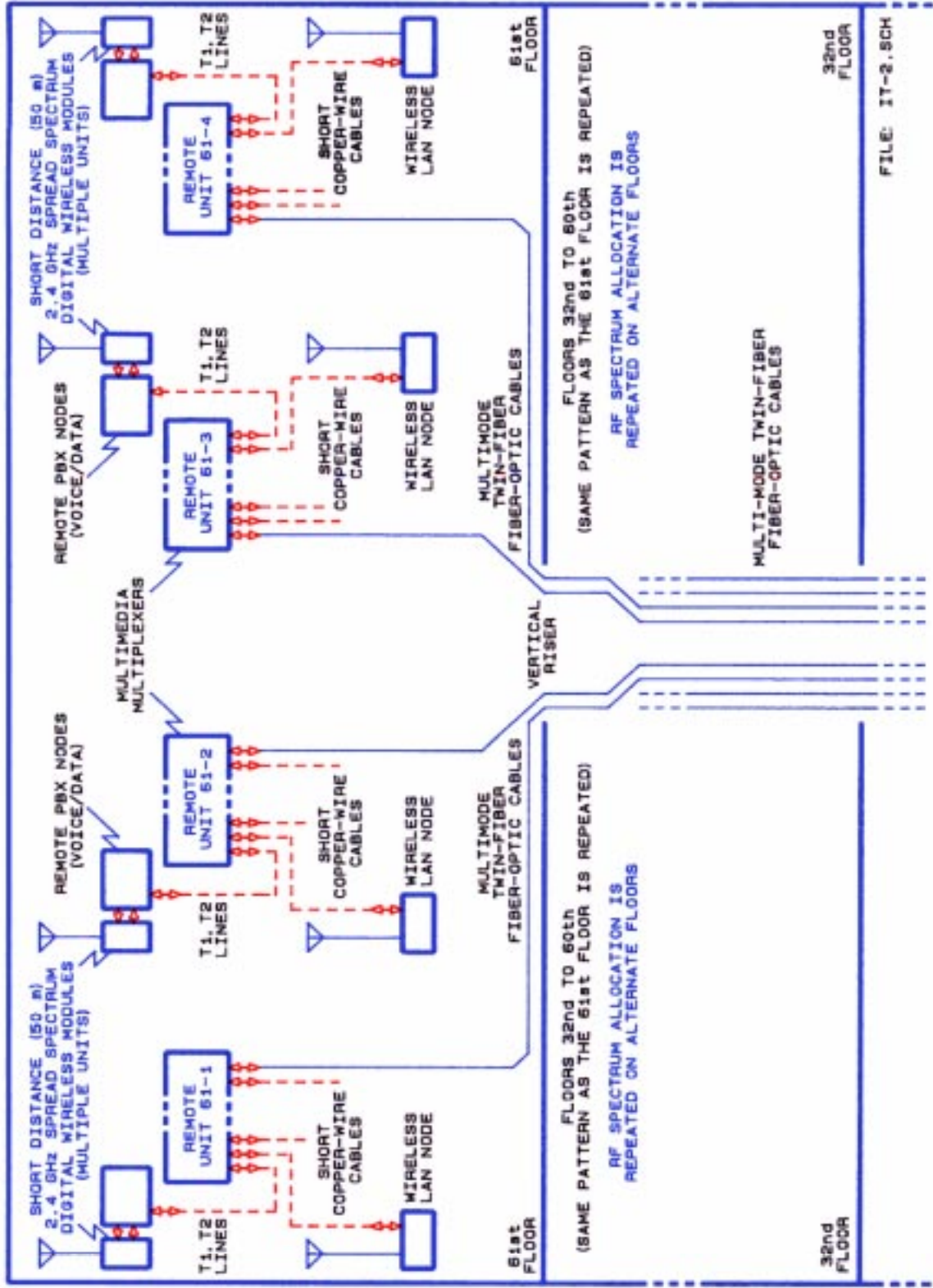

FIG. 2-A FIBER OPTIC & WIRELESS HYBRID MULTIMEDIA
PREMISES WIRING SYSTEM (UPPER FLOORS)

Figure 2-B shows a block diagram of the Computer & Control Room that houses all the equipment to meet the Fourth Utility needs of an intelligent building.

For obvious reasons, the Computer & Control Room is designed to be secure from unauthorized entry. The room is also fire-proofed thoroughly. Back-up electrical power should also be provided.

The main-units of the multimedia multiplexers separate out each of the signal channels through interface cards. Short copper-wire interconnections are then used to route the channels to different systems. Some of the systems are discussed in the following sections.

5.1.1 HVAC and Lighting Control Systems

The HVAC Control system is linked through the multimedia multiplexers, to all sensors and control units on every floor. Similarly, the Lighting Control System is also connected to all light sensor & control units of the building.

Both the HVAC Control and Lighting Control Systems can be under time-scheduled control. They can also respond to special demands such as after-hours work in specific areas of the building. In this case, linkage with Access Control Systems will be desirable in order to allow automatic adjustments of the HVAC and lighting.

5.1.2 Access Control and Pager Systems

Where there is a need such as in the case of a multi-tenant building, multiple Access Control Systems can be supported readily. Modifications associated with tenant moves can be made easily because only short copper-wire cables and interface cards need to be changed.

Similarly, multiple pagers that include a location indicator can also be installed. This system might be combined with the Access Control System to monitor the after-hours location of people in the building, just in case there is an emergency, or there are unauthorized movements. Again, changes are simple to implement.

5.1.3 Fire Detection and Mist-Sprinkler Control Systems

Sensors are placed throughout the building to monitor temperature and smoke density to detect a fire. The rates of change of temperature and smoke density are also taken into account to determine whether there is a fire.

This method is much more sensitive than standard smoke detectors and even more sensitive than the release mechanisms of standard sprinkler heads. Therefore, early detection and control of fires is possible.

Once the presence of a fire is determined by the system, fine-spray mist-sprinklers located near the fire are activated automatically by electrically heating a release-capsule that is identical to those used in standard sprinkler heads.

Alarms are also triggered and voice messages are transmitted through telephone lines to the proper authorities. Signals to the PA (Public Address) system activate voice announcements as well.

Furthermore, a communication link to the HVAC Control System allows activation of various air pressurization and ventilation measures such as removal of smoke from escape routes.

The fine-spray mist is very effective in extinguishing fires. Experiments by the Tokyo Metropolitan Fire Department have shown that automobile fires in building garages are put out in a very short time compared to the case where standard fire hoses are used. Also, the fine-spray mist causes much less water damage compared to standard sprinklers. Even electronic equipment has a chance of surviving exposure to mist.

Since the fine-spray mist-sprinkler heads can be activated individually, either as an automatic response to a fire, or manually through computer control, a fire can be fought intelligently.

In other words, a fire can be contained by manually activating the fine-spray mist-sprinklers close to the fire. In fact, a fire in a building can be

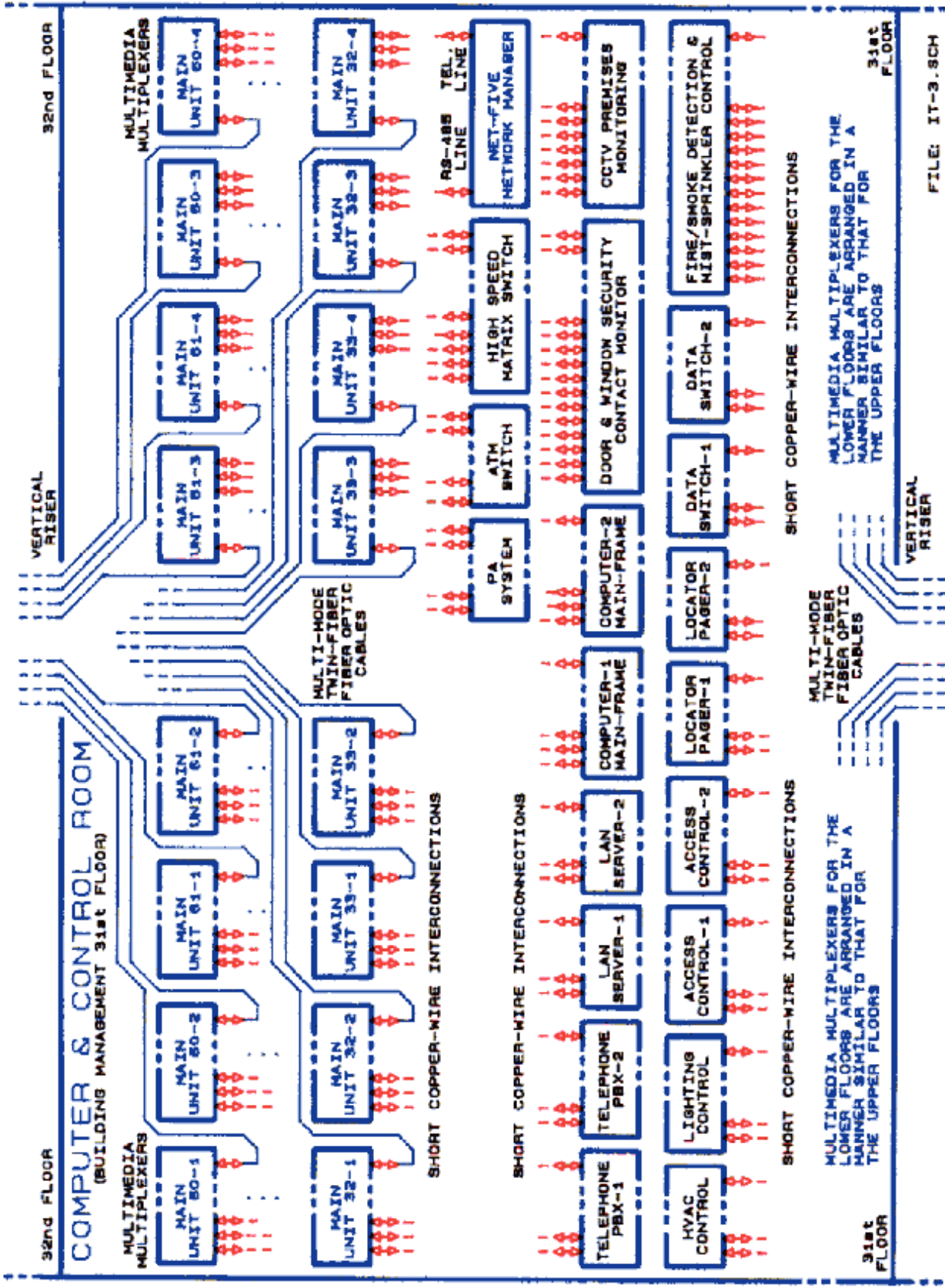

FIG. 2-B FIBER OPTIC & WIRELESS HYBRID MULTIMEDIA PREMISES
 PREMISES WIRING SYSTEM (COMPUTER & CONTROL ROOM)

fought from the Computer & Control Room or from a remote location through a data line connected to the PC for the system.

Fine-spray mist-sprinkler heads should be installed in the standard sprinkler system. This way, the safety of a building is doubly assured by the presence of a back-up system in the form of standard sprinkler heads. Since the fine-spray mist is distributed throughout the room by air currents generated by the sprinkler head itself, only a minimum number of heads are required for each room.

The various functions described here are already available in many building management & control systems. Regretfully, the Fire Detection and Mist-Sprinkler Control System is not on the market yet. However, it has been prototyped and successfully tested in a laboratory at the University of Regina.

5.1.4 Door & Window Security Contact Monitoring System

Since contact closures require very low bit rates (e.g. < 1 b/s) to transmit the information, the multimedia multiplexer has ample capacity to support many security contacts in a building.

When the Contact Monitoring System detects unauthorized entry, alarms can be activated and authorities notified through a telephone line.

5.1.5 CCTV Premises Monitoring System

The CCTV system was included in the design, anticipating the availability of low cost A/D (Analogue to Digital) encoders and D/A (Digital to Analogue) decoders for video signals.

Recent developments in DVD (Digital Versatile Discs) and digital video cameras indicate that in the near future, the cost of encoder and decoders will be sufficiently low to allow competition with analogue systems.

If the MPEG-2 (Motion Picture Engineering Group 2) standard is followed, about 6 Mb/s of channel capacity will provide a satisfactory picture that meets cable TV standards. Since

only 6 Mb/s per channel is needed, interface cards to support digital CCTV can be fabricated easily.

Even if the encoder and decoder costs are of the order of \$ 100, elimination of most of the coaxial cables or separate fiber-optic cabling by the universal premises wiring system discussed here, will make the digital CCTV system competitive with current analogue systems.

5.1.6 Cable TV

A cable TV system is not mentioned specifically in this design. However, once low cost digital TV encoders and decoders become available, installation of digital cable TV signal sources and a matrix switch using spatial (i.e. circuit) switching methods in the Computer & Control Room will support full cable TV services.

By using a low-bit rate (e.g. 16 kb/s) data channel, a user can select a cable TV channel by signaling the matrix switch. Interface cards for the digital cable TV signals are simple to make because only 6 Mb/s is required out of the 100 Mb/s capacity of the multimedia multiplexer.

5.1.7 Telephone Service

Telephone service is provided through digital PBXs that support remote nodes through T1 = 1.544 Mb/s channels. Many manufacturers offer such systems today to reduce the total length of copper-wire used in large buildings.

For multi-tenant buildings, separate PBXs can be installed for each tenant if the demand exists. They need not be from the same manufacturer because T1 interface cards will support standard T1 channels. Also, shared-tenant services can be offered if there is a demand.

It should be noted that there is little danger of cross-talk of telephone signals within the multiplexer since time division multiplexed transmission is used and each telephone signal occupies its own independent time-slot. In other words, each of the multiple PBXs is independent and as secure as having separate copper-wire networks.

Since only short copper-wire cables and interface cards need to be changed, upgrades and modifications are carried out easily.

5.1.8 Data Services, LANs and High Speed Ethernet LANs

Connection of PCs to the Internet can be supported with data lines provided through a PBX or high-speed (e.g. T1) wireless modules. Interconnections between computer terminals or PCs to computer main-frames are provided through specific interface cards designed to support a wide range of bit rates (e.g. 14.4 kb/s, T2 = 6.312 Mb/s, 20.0 Mb/s). Computer mainframes can be owned by individual organizations or provided on a shared basis.

Interface cards for ATM (Asynchronous Transfer Mode) channels can also be assembled easily. Therefore, connections to an ATM Switch are supported with little difficulty. Similarly, connections to many data switches and high-speed spatial matrix switches on the market today can be supported as well.

Using interface cards such as those designed as Ethernet bridges and Token-Ring repeaters, interconnections can also be provided to multiple LAN servers. Such interface cards are not difficult to fabricate.

By using Ethernet bridges, 100 MHz and GHz Ethernets can be supported with ease. The best approach is to install Ethernet bridges in the remote-units of the multimedia multiplexers located on each floor.

The bridges support local segments of a 10 MHz Ethernet. If the total number of users per segment is restricted to less than 30, very efficient service can be maintained. Extra Ethernet bridges can be installed to support additional users.

Wireless LAN nodes can also be used to connect the Ethernet bridge interface card to users.

The Ethernet bridge can be designed to have a bi-directional data transfer rate of 20Mb/s in both directions. Hence, there will be little or no

problem with congestion even if all 30 users are on-line.

The signals (i.e. Ethernet frames) not belonging to the local segment are forwarded to the corresponding Ethernet bridge interface card in the main-units of the multimedia multiplexers located in the Computer & Control Room.

Groups of the 10 MHz Ethernet bridge interface cards can then be connected to 100 MHz Ethernet segments where each segment supports a maximum of 300 users. One or more servers may be connected to a 100 MHz Ethernet segment.

Note that each group of 10 MHz Ethernet bridge interface cards can be those belonging to a single tenant in a multi-tenant building. In other words, a single 100 MHz Ethernet segment might serve a single tenant.

The 100 MHz Ethernet segments can be connected to a GHz Ethernet that is served by one or more servers. In a multi-tenant building, separate GHz Ethernets may be installed to independently accommodate each tenant. In other words, a separate GHz Ethernet can serve each tenant. Of course, tenants can have their own server if they wish.

As mentioned earlier, the wiring system discussed here has no cross-talk problems within the multiplexers and fiber-optic cables. Therefore, data service and LAN connections are secure and are equivalent to those provided through independent copper-wire or fiber-optic networks.

5.1.9 Network Manager

The Network Manager is a PC with appropriate software for network management. It is connected to all main-units of the multimedia multiplexer-pairs through an RS-485 bus. The Network Manager PC accesses the remote-units of the multiplexer-pairs through a housekeeping data channel linking the multiplexer-pair.

The Network Manager monitors the operational status of each of the multiplexer-pairs as well as the interface cards in the multiplexers.

When serious malfunctions arise in the premises wiring system, a telephone modem installed in the Network Manager PC is used to automatically alert the appropriate personnel.

Records of channel assignments and user information can also be maintained. Therefore, network reconfigurations and upgrades are planned with ease and carried out readily.

6. ADVANTAGES

Table 2 summarizes the advantages of the Fiber-Optic & Wireless Hybrid Multimedia Premises Wiring System. As mentioned earlier, the system corresponds to Layer 1 of the OSI (Open System Interconnect) 7-Layer Model established by ISO (International Standards Organization).

**TABLE 2
ADVANTAGES**

- OSI Layer-1 (Physical Layer)
- Standard Connections
- Transparent to Application Engineer

- Fiber-Optic Cables
 - No Cross-Talk
 - No Ground Loops
 - No EMI
 - No RFI
 - No Post-Installation Headaches

- Large Network Capacity

- More than 80 % of Copper-Wire Eliminated
- Lower Overall Cost
- Reliable
- Network Manager
- Multiple Independent LANs Supported

- Multiple Independent PBXs Supported
- Easy Maintenance and Upgrading

Therefore, the system is equivalent to many different copper-wire networks that are independent from each other. In other words, the system is transparent to the application engineer and only standard copper-wire connections need to be considered.

Fiber-optic cables, of course, have no cross-talk between optical fibers. In contrast, cross-talk can be a serious problem in copper-wire networks and some are unable to operate reliably. Even coaxial cables may have difficulties unless they have solid metal shielding.

The absence of cross-talk means that mechanical stresses are the main concern when installing fiber-optic cables. In contrast, installation of copper-wire cables must take into account not only mechanical stresses, but also the presence of cross-talk between different wires. Furthermore, compared to copper-wire cables, fiber-optic cables are much lighter and easier to install. Hence, the installation cost of fiber-optic cables is lower.

Since optical fibers are insulators, there are no ground loop problems with fiber-optic cables. Ground loops can be a serious problem for copper-wire cables because the difference in electrical potentials between equipment can be large in high-rise buildings. As a result, the leakage current could reach magnitudes where serious damage to equipment might be caused and fires started.

Of course, there are neither EMI (Electromagnetic Interference) nor RFI (Radio Frequency Interference) problems with fiber-optic cables because the frequencies of the optical signals are clearly out of the range of EMI and RFI frequencies. Therefore, fiber-optic cables can be installed without concern for EMI and RFI from electrical and electronic equipment, which are abundant in high-rise buildings.

Clearly, the absence of ground loop, EMI and RFI problems in fiber-optic cables eliminates most of the post-installation headaches associated with such problems in copper-wire cables. Indeed, the cost of correcting such problems can be very expensive.

A very large transmission capacity is supported by a star-network. For the 61-story high-rise office building discussed in Figs. 2-A and 2-B, the total number of multimedia multiplexer-pairs is $4 \times 60 = 240$. Since each pair has a transmission capacity of 100 Mb/s, a floor is served by a capacity of

$$4 \times 100 \text{ Mb/s} = 400 \text{ Mb/s}$$

and the entire building has a capacity of

$$\begin{aligned} 240 \times 100 \text{ Mb/s} &= 24,000 \text{ Mb/s} \\ &= 24 \text{ Gb/s.} \end{aligned}$$

Because of the multiplexing, a much smaller number of fiber-optic cables are used compared to the number of copper-wire cables of equivalent telecommunication capacity. In fact, the combined use of fiber-optic cables, multimedia multiplexers and wireless modules eliminates more than 80 % of copper-wire cables of the Fourth Utility. This means that the cross-section of vertical risers can be smaller, thereby releasing floor space for other uses.

Furthermore, as mentioned earlier, fiber-optic cables are much lighter than copper-wire cables. Therefore, installation of fiber-optic cables is completed in a shorter time.

Obviously, compared to standard copper-wiring, significant savings can be realized by the Fiber-Optic & Wireless Hybrid Multimedia Premises Wiring System because upgrades and modifications involve only short copper-wire connections and simple unplug and/or plug-in operations of interface cards. Figure 3 represents the possible cost savings in a simple, graphical manner.

Many years in the past, the higher cost of word processing machines compared to IBM electric typewriters used to be questioned. Today, PC word processing is accepted without questions, despite their higher cost. Clearly, the improvement in productivity more than offsets the higher initial cost.

In a similar fashion, the Fiber-Optic & Wireless Hybrid Multimedia Premises Wiring System will provide high returns for a relatively small additional investment at the beginning. Calculations have shown that the maintenance costs, rewiring costs associated with office moves, tenant changes, alterations and upgrades can be reduced by more than a factor 2 over the lifetime of a building.

In addition, the system is very reliable because breakdown in a pair of multimedia

multiplexers affects only a small section of a building. Constant monitoring by the Network Manager PC allows quick response to breakdowns.

Maintenance and upgrading can be as simple as replacing interface cards because the Network Manager maintains a database on various interface cards in each multiplexer. The database also allows efficient planning of upgrades.

In the case of upgrading to GHz Ethernet services when the system becomes available at reasonable cost, no rewiring of the building is required. The GHz Ethernet can be installed inside the Computer & Control Room and segments of the 100 MHz Ethernet can be connected to the GHz Ethernet. The length of interconnections need not be long because the 100 MHz Ethernet segments are all located within the Computer & Control Room. Short interconnections should ease the installation of GHz Ethernets.

Since the system is equivalent to many independent copper-wire networks, installation of multiple PBXs, data switches and LANs is supported readily. The system is ideal for multi-tenant buildings or intelligent buildings for large corporate headquarters.

7. DISCUSSION

Today, the premises wiring scene is disorganized to say the least. Wiring for building management & control systems such as HVAC, access control and door & window security, are frequently installed independently. Similarly, wiring for telephones and LANs are installed separately in many cases.

Without a coherent wiring strategy, problems such as inefficient use of raceways and conduits, EMI, RFI and cross-talk problems are often encountered. Post-installation remedies can be expensive.

Reorganization of the premises wiring scene can be realized by what might be called the "Fourth Utility Entity". It should be responsible for designing and supervising the installation of Fourth Utility systems. Only then will the separate

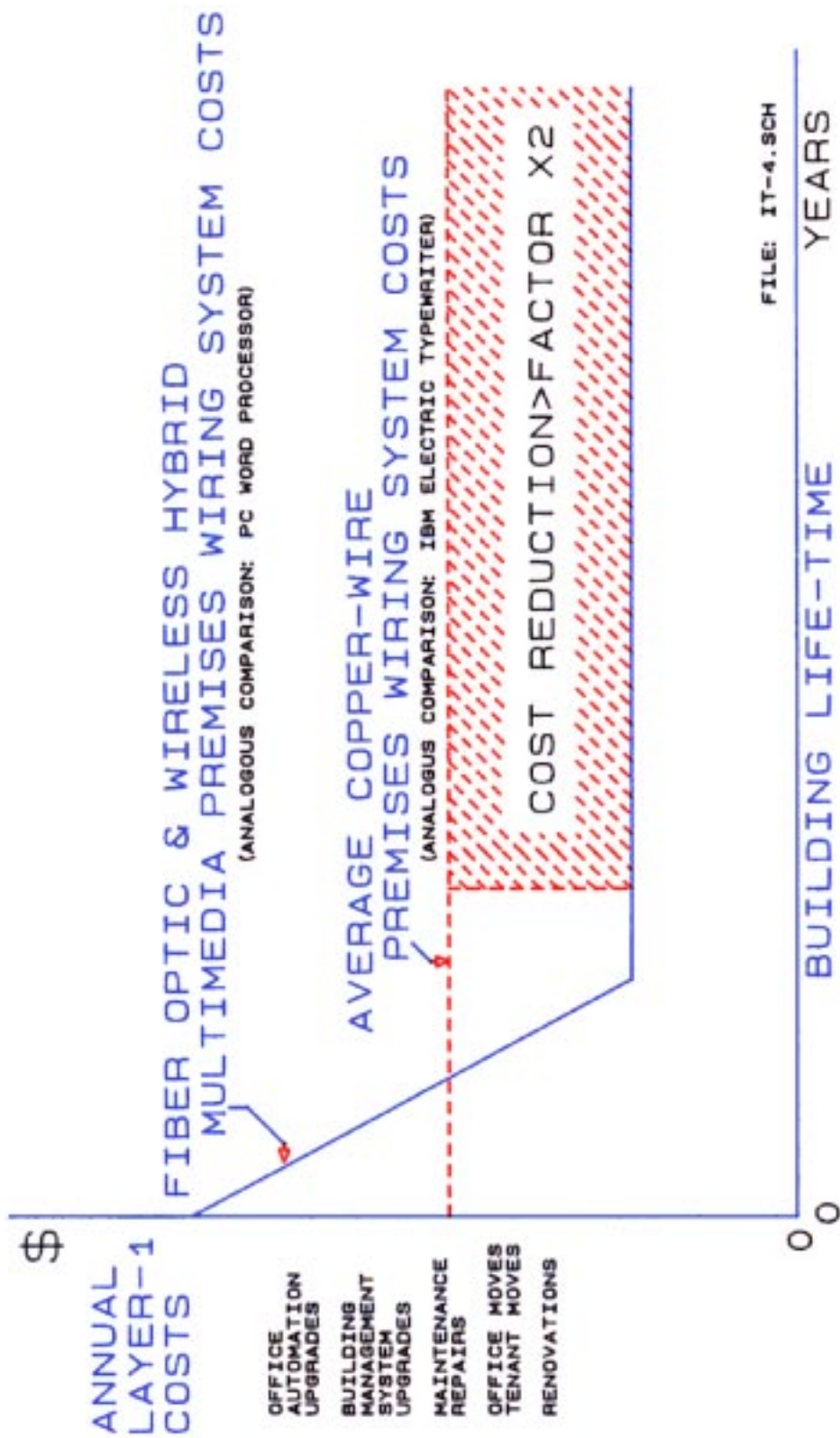

FIG. 3 PREMISES WIRING SYSTEM COMPARATIVE COSTS

wiring schemes be brought under a coherent plan and the full economic advantages of a Fourth Utility system realized.

Although an acceptable Fourth Utility system might be attained with some difficulty by using copper-wire cables, the Fiber-Optic & Wireless Hybrid Multimedia Premises Wiring System offers a superior Fourth Utility system with significant economic advantages

All the equipment and systems mentioned in the preceding sections are either on the market today, or can be produced readily with the technologies already on hand. The multimedia multiplexer has already been prototyped and field-tested at the University of Regina.

Wide scale acceptance of the Fourth Utility concept must await the enlightenment of developers and construction industry. Demands for better Fourth Utility services by tenants and users might accelerate such acceptance.

APPENDIX

FIBER-OPTIC MULTIMEDIA MULTIPLEXER

A-1. INTRODUCTION

A multimedia multiplexer must be universal in its function and accept a wide range of digital signals from DC to more than 50 Mb/s. Analogue signals ranging from audio to baseband video should also be supported. Of course, analogue signals are digitized before multiplexing and converted back to analogue form after demultiplexing.

To accommodate a wide range of multimedia signals, interface cards are used for each specific application. Most cards operate in a bi-directional manner, providing or recovering specific digital signals to and from the main multiplex-demultiplex operations.

Table A-1 lists the different multiplexing operations used by the multimedia multiplexer. The high-speed asynchronous over-sampling method samples the signal at a rate about 10 times that of the signal and multiplex transmits the samples. Because of the over-sampling, no timing adjustments are required between the signal and the multiplexer sampling rate.

Therefore, the multiplexing circuitry for over-sampling is simple. However, since the sampled bit rate is 10 times that of the signal, the method is best used for digital signals with bit rates less than 200 kb/s.

The basic clock frequencies matching that of the multimedia multiplexer are used in synchronous multiplexing. Therefore, little or no timing adjustments are required. This method is used mainly for multiplexing many signals with the same bit rate.

Synchronous bit stuffing and de-stuffing is used to match the difference in the signal bit rate and the clock frequency of the multimedia multiplexer. Extra bits are added before multiplexing and removed after demultiplexing. Components such as FIFO (First-In First-Out) buffers are used

to perform this operation. A VCO (Voltage Controlled Oscillator) recovers the signal clock after the demultiplexing operation.

TABLE A-1
MULTIPLEX OPERATIONS

- High Speed Asynchronous Over-Sampling
 - No Adjustment for Clock Rates
 - Simple Circuitry
 - Bit Rate = (Signal Bit Rate) X 10
- Synchronous Multiplexing
 - Same Clock Rates
 - Efficient
 - Standard Circuitry
- Synchronous Bit Stuffing & De-Stuffing
 - Match Clock Rates
Different from the Multiplexer
 - FIFO Circuitry

The wide range of demands made on a multimedia multiplexer may appear to be difficult to accommodate by standard electronic components. Fortunately, the AMD (Advanced Micro Devices, Inc.) TAXIchip IC (Integrated Circuit) allows a fiber-optic multimedia multiplexer to be fabricated without much difficulty. The following chapter describes the design.

A-2. FIBER-OPTIC MULTIMEDIA MULTIPLEXER

Figure A-1 shows the basic idea of the design. The multiplexer TAXIchip accepts ten 10 Mb/s channels and multiplexes them into a 100 Mb/s signal. Addition of housekeeping signals results in a multiplexed bit stream of 125 Mb/s. This is provided to a fiber-optic transmitter module.

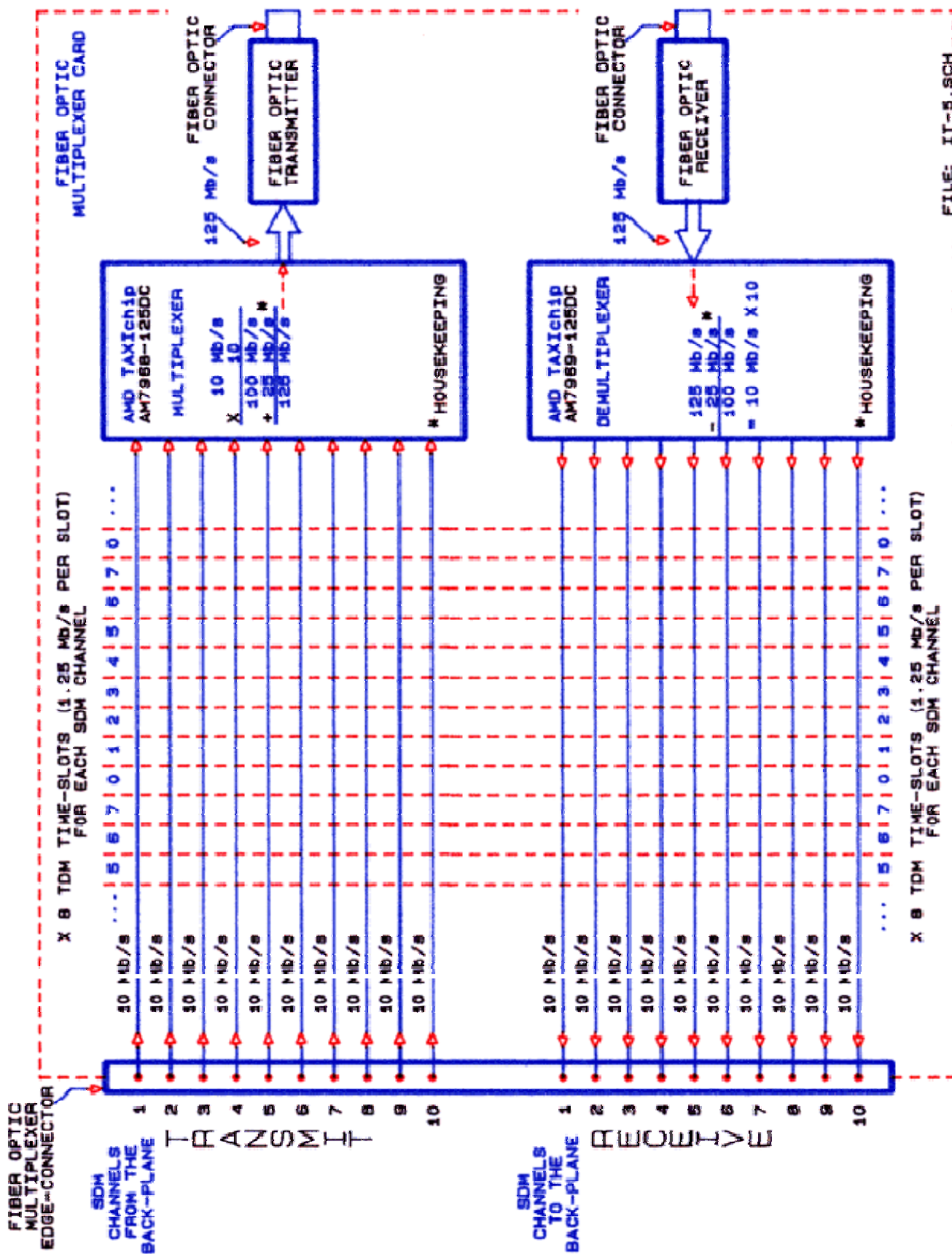

FILE: II-9.SCH

FIG.A-1 FIBER-OPTIC MULTIMEDIA MULTIPLEXER

The demultiplexer TAXIchip demultiplexes the 125 Mb/s signal received from the fiber-optic receiver module, into ten 10 Mb/s channels. Two pairs of fiber-optic multiplexer-demultiplexers constitute a bi-directional fiber-optic multimedia multiplexer system.

The fiber-optic multiplexer circuit is fabricated on a printed circuit board and inserted into an edge-connector on a back-plane that fits into a housing for 19" racks.

The 10 Mb/s channels form two sets (i.e. Transmit & Receive) of 10 SDM (Spatial Division Multiplex) channels extending along the back-plane. Each of the ten 10 Mb/s Transmit SDM channels are divided into eight 1.25 Mb/s TDM (Time Division Multiplex) time-slots. Thus, a total of 80 time-slots are provided. Similarly, Receive SDM channels are divided into 80 TDM time-slots.

All TDM time-slots are made available to all interface cards through the SDM channels. They are utilized as the application demands. Note that a TDM time-slot can be subdivided further to multiplex very low bit-rate signals.

Figure A-2 schematically shows the SDM channel layout of the back-plane. A series of reference clocks are also available for use by the interface cards when required. Thirteen edge-connectors are provided for the interface cards.

An interface card selects one or more of the SDM channels as needed, by establishing physical contact through the edge-connector. One or more TDM time-slots of the chosen SDM channels are then selected by 3-bit binary codes. Mechanical switches set the codes.

Figure A-3 shows the arrangement for the time-slots of the Receive SDM channels. The arrangement is identical to that of the Transmit SDM channels. The logic levels of the switch-selected 3-bit binary codes choose the specified time-slots electronically. By choosing a combination of any number of SDM channels and TDM time-slots, interface cards can support a wide range of multimedia signals.

Table A-2 lists the fiber-optic multiplexer-demultiplexer cards that have been prototyped and successfully tested. The microcontroller in

TABLE A-2

**FIBER-OPTIC
MULTIPLEXER-DEMULTIPLEXER CARDS**

- **HOUSING:**
 - EUROPAC Rational 19" Card Cage
25.4 mm Slots X 14
Height 6U = 266 mm
Width 84HP = 427 mm
Depth = 140 mm
- **MAIN CARD:**
FIBER-OPTIC TRANSCEIVER &
MULTIPLEXER-DEMULTIPLEXER
 - LED or LD (Wavelength = 1300 nm)
 - Transmission Distance
LED = 3 km or LD = 10 km
 - Data Rate = 100 Mb/s
X 80 1.25 Mb/s Time Slots
 - Alarms
Low Optical Power
Loss of Synchronization
Automatic Transfer to Back-Up Card
 - Network Manager Microcontroller
Network Manager PC Access via
RS-485 Data Bus (RJ-45 Jack)
- **MAIN BACK-UP CARD (OPTIONAL):**
FIBER-OPTIC TRANSCEIVER &
MULTIPLEXER-DEMULTIPLEXER
 - Same as Main Card less Microcontroller
- **REMOTE CARD:**
FIBER-OPTIC TRANSCEIVER &
MULTIPLEXER-DEMULTIPLEXER
 - Same as Main Card
less RS-485 Data Bus (RJ-45 Jack)
 - Access to Main Card Microcontroller
via 1.25 Mb/s TDM Time-Slot
- **REMOTE BACK-UP CARD (OPTIONAL):**
FIBER-OPTIC TRANSCEIVER &
MULTIPLEXER-DEMULTIPLEXER
 - Same as Remote Card
less Microcontroller

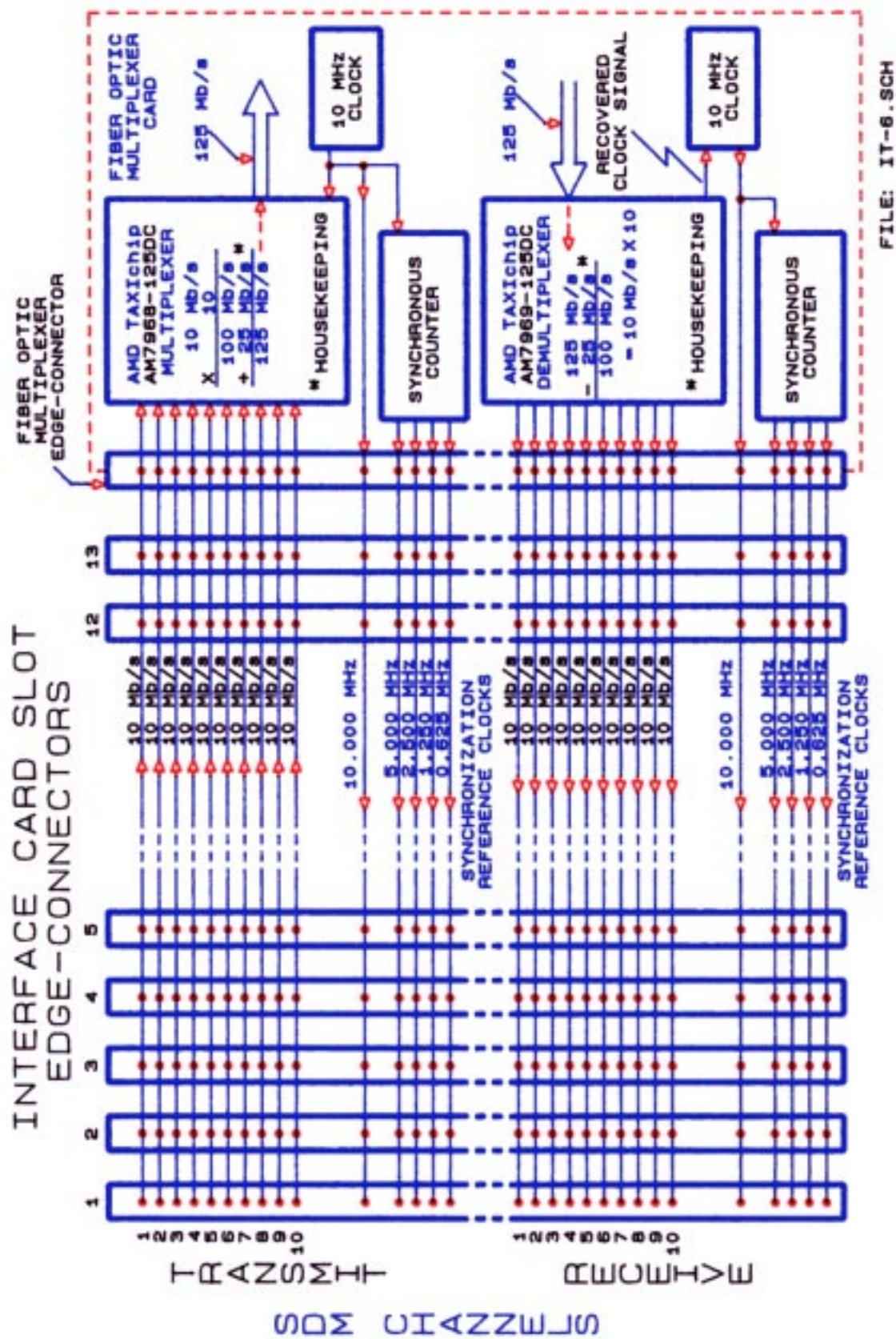
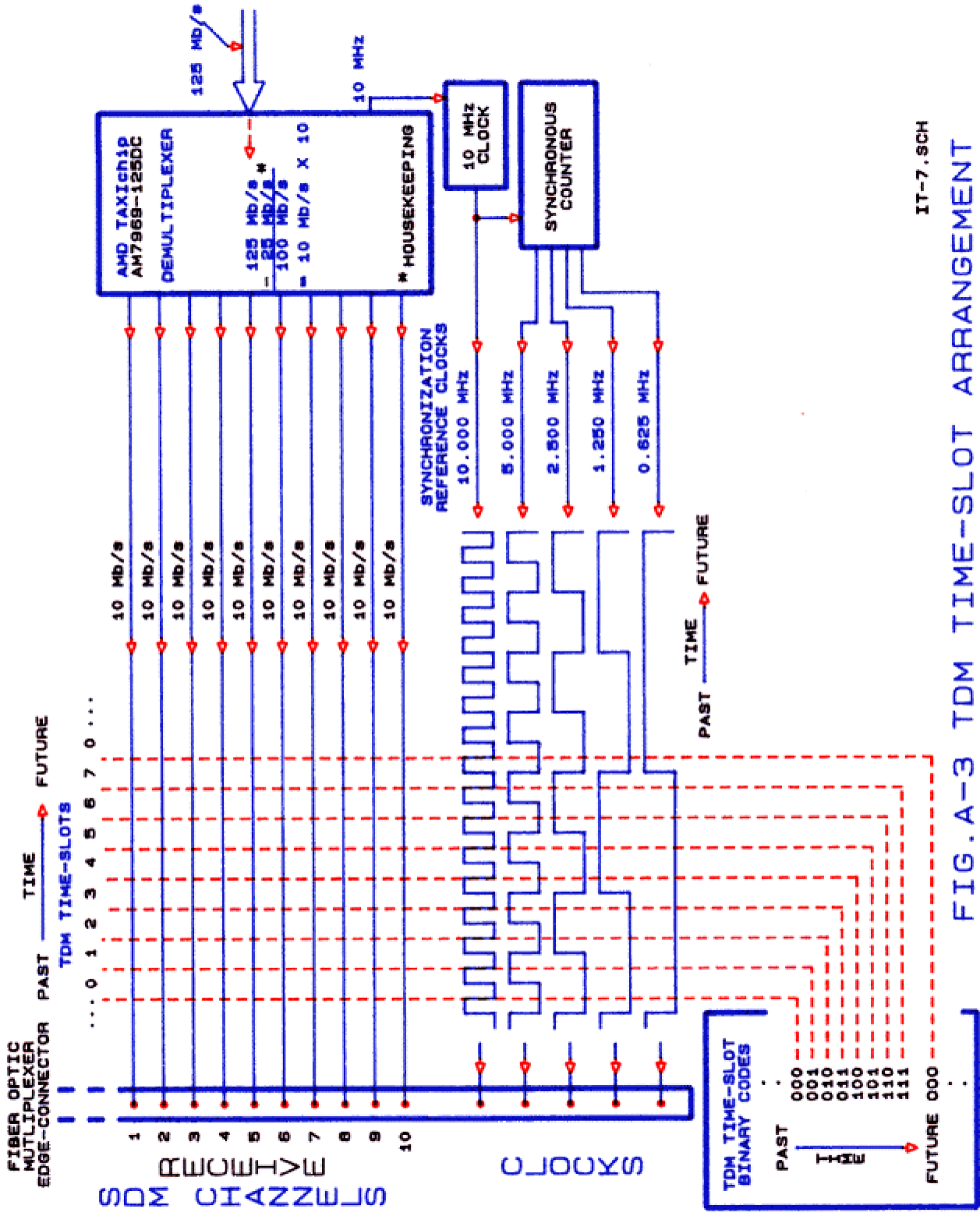

FIG. A-2 BACK-PLANE SDM CHANNEL LAYOUT



IT-7.SCH

FIG. A-3 TDM TIME-SLOT ARRANGEMENT

the Main Card is linked to the Network Manager PC through an RS-485 data bus.

The microcontroller in the Remote Card is linked to the microcontroller of the Main Card by using one of the 80 1.25 Mb/s TDM time-slots. Through these interconnections, the Network Manager PC monitors the operational status of the multiplexer pairs and all of their interface cards. Records of the SDM channel and TDM time-slot allocations are also maintained to avoid duplicate usage.

For future development, all of the interface cards might have electronic switches installed to select SDM channels as well as TDM time-slot allocations. By controlling these electronic switches remotely from the Network Manager PC, allocation of the SDM channels and TDM time-slots can be managed in a systematic manner.

The high reliability of fiber-optic systems makes a back-up system redundant. However, Back-Up Cards were made to meet the needs for very high reliability. In case of a failure either in the Main Card or the Remote Card, the microcontrollers transfer the operation to the Back-Up Cards.

Table A-3 lists some of the interface cards that have been developed and tested successfully. The RS-232C, RS-422 and RS-485 cards use high speed over-sampling at a 1.544 Mb/s rate. As a result, bit rates up to 150 kb/s can be transmitted. Experimentally, the cards function satisfactorily even at 300 kb/s.

The Ethernet Half-Bridge examines the frame addresses and transfers the frames that do not belong to the local segment, to the other Half-Bridge in the far multiplexer. The transfer rate can be set at 20 MHz to eliminate any bottleneck at the bridge.

Interface cards for digital signals can be fabricated without too much difficulty once the signal bit rate, voltage, and line impedance are known. Similarly, interface cards for analogue signals are also fabricated readily once the digitized bit rate is known. The availability of 80 TDM time-slots at 1.25 Mb/s reduces the task to a relatively simple one.

Net-Five Telecom Corporation and Canadian Institute for Broadband and Information Network Technologies worked together at the Faculty of Engineering of University of Regina to develop the Fiber-Optic Multimedia-Multiplexer discussed here.

A U.S. Patent, "Digital Multiplexer with Logically Allocatable Channels and Bit Rates", No. 5,315,596 (1994/05/24), was granted for the design discussed here in the Appendix. Patents have also been obtained in Japan, Korea and the Peoples' Republic of China

TABLE A-3

INTERFACE CARDS

- RS-232C 6-Channel, DC - 150 kb/s
- RS-422 4-Channel, DC - 150 kb/s
- RS-485 4-Channel, DC - 150 kb/s

- Hi-Fi Input 2-Channel
Analogue 30 Hz - 20 kHz
- Hi-Fi Output 2-Channel
Analogue 30 Hz - 20 kHz

- Order-Wire Telephone 2-Channel
- Relay Contact Closure 16-Channel

- T1 = 1.544 Mb/s 4-Channel
T1 = 2.048 Mb/s 4-Channel

- Ethernet Half-Bridge
10 MHz or 20 MHz Transfer Rate